

# HEAVY-DUTY CAMERA

WHITE LIGHT FULL-COLOR OR INFRARED

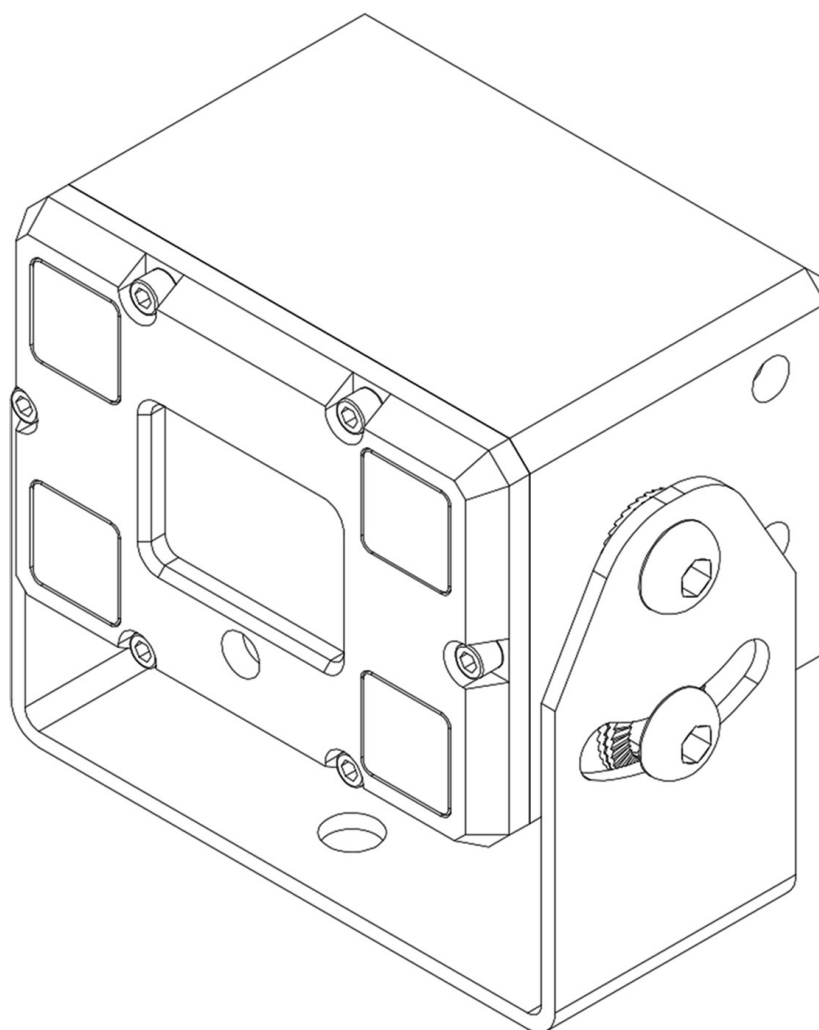

**WDM-MC4000B/-VA-(EMPTY/A/IP)**

304 stainless steel steel

Install and operation instruction

# WDM-MC4000B/-VA-(Empty/A/IP)

## HEAVY-DUTY FULL COLOR OR INFRARED CAMERA

---

### Contents:

<b>1.Product description</b>	<b>4</b>
1.1、 Important information about the product .....	4
1.2、 Technical data .....	5
1.3、 Appearance and Installation Dimensions .....	6
1.4、 Plug connection.....	6
1.5、 Horizontal view angle .....	6
<b>2.Safety precautions</b>	<b>7</b>
2.1 Product safety .....	7
2.2 Additional dangers .....	7
<b>3.Commissioning</b>	<b>8</b>
3.1 Assembly.....	8
3.2 Electrical connection .....	9
3.3 Functional check and camera adjustment .....	9
3.4 Faults .....	9
<b>4、 Customer information</b>	<b>9</b>
4.1 Maintenance/Cleaning .....	10
<b>5、 Environmental protection</b>	<b>10</b>

# WDM-MC4000B/-VA-(Empty/A/IP)

## HEAVY-DUTY FULL COLOR OR INFRARED CAMERA

---

### General information about operating instructions

Thank you for choosing Wardmay products. We develop and manufacture our products with the greatest possible care. If you have any questions with regard to the product, putting it into service, or its operations, or should the product not meet your expectations, please feel free to talk to us about it at any time.

Please read the operating manual in full and attentively before using the product. It must be retained for later use. Our products are subject to continuous further development.

### 1.Product description

Cameras of the **WDM-MC4000B** is a kind of compact anti-corrosion camera which is widely used in heavy or large mobile equipment, such as mobile cranes, forklifts, tower cranes, marine, excavators, loaders, aerial cranes and so on.

The main characteristics are as follows:

- ❖ Adopt 304 stainless steel material ensures its own durability and can also cope with more complex working environments
- ❖ The camera glass is made of thick and highly transparent tempered glass which can withstand stronger impacts;
- ❖ Built in 2.5W automatic heating system, which can cope with situations where it cannot be used normally due to icing in extreme low temperature weather (optional);
- ❖ Adopt Sonny ultra-low illumination chip, combined with F1.0 lens, which can achieve full color starlight image;
- ❖ Adopt double-tooth self-locking design which can handle the situation where the mobile device is vibrated and causes the image offset;
- ❖ Following the explosion-proof design concept, the whole camera adopts isolation design to avoid the phenomenon of equipment being unable to work normally due to electric shock caused by the housing.

#### 1.1、 Important information about the product

# WDM-MC4000B/-VA-(Empty/A/IP)

## HEAVY-DUTY FULL COLOR OR INFRARED CAMERA

Make certain based on the information on the monitor rating plate that the device type matches these operating instructions. For further instructions, please consult the operating instructions for the connected cameras or video control units.

### 1.2、 Technical data

Technical Data	CCD	AHD (4 In 1)	6MP (IP)
Image sensor	1/3" Sony CCD Sensor	1/2.8" Sony Sensor	1/2.8" Sony Sensor
Resolution	976 (H) × 582 (V)	1920 (H) × 1080 (V)	2592 (H) × 1944 (V)
High light sensitivity	0.005Lux	0.0001Lux@F1.2	0.0001Lux@F1.2
Image processing	Auto-exposure, automatic white balance Dynamic gamma correction, tone-mapping, overlays		
Lens	2.8/3.6/4/6mm (Horizontal view angle:40°/70°/90°/100°/115°)		
Night Vision Distance	Up to 25 m visibility in the dark		
Housing	304 Stainless Steel		
Housing protection class	Safe against condensation and jet washers (IP68 and IP69K)		
Degree of protection	Resistant to immersion in water and high- pressure cleaners (IP68 and IP69K)		
Mechanical resistance	Specially for heavy-duty applications, shockproof to100g, vibration resistant to 10g in accordance.		
Power consumption	Max. 3W (incl. Heating)		
Power supply	12V DC For standard (9~32V DC customized)		
Operating temperature	-50 °C.+85 °C		
Video System	PAL/NTSC		
Weight	1 Kg		
Package contents	WDM-MC4000B heavy-duty camera / Bracket set / Operating instructions		

# WDM-MC4000B/-VA-(Empty/A/IP)

## HEAVY-DUTY FULL COLOR OR INFRARED CAMERA

### 1.3、 Appearance and Installation Dimensions

All dimensions in mm

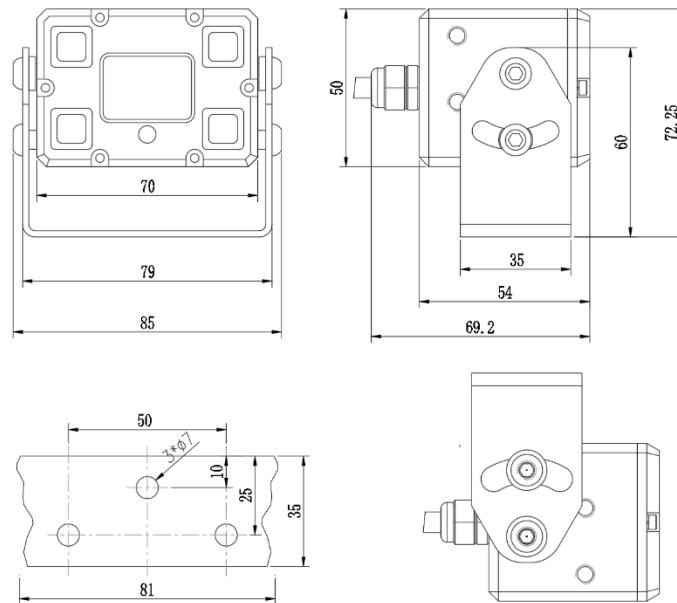

### 1.4、 Plug connection

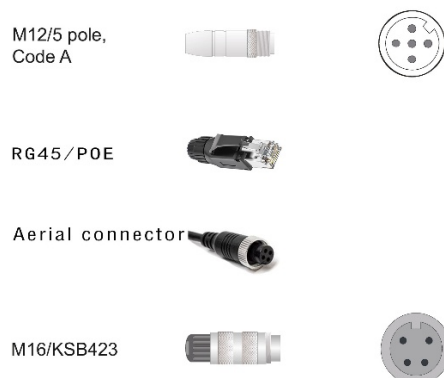

### 1.5、 Horizontal view angle

Schematic representation

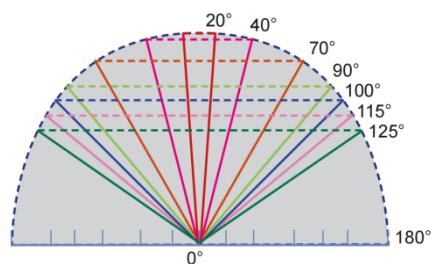

# WDM-MC4000B/-VA-(Empty/A/IP)

## HEAVY-DUTY FULL COLOR OR INFRARED CAMERA

---

### 2. Safety precautions

- ❖ The electrical connection and initial commissioning must only be performed by a knowledgeable specialist in conformity with the instructions in these operating instructions.
- ❖ The devices must only be placed in operation if the user is aware of the risks and dangers resulting from the use of the device.
- ❖ Damaged devices must not be placed in operation.
- ❖ A direct connection on the AC network is not permitted.
- ❖ The fuse which has been pre-connected to the camera may not be bridged or removed. A defective fuse must be replaced with the prescribed current value.

### 2.1 Product safety

The product is designed to the state of the art and meets the requirements of generally recognized safety rules. The system must only be operated in flawless condition and in accordance with the instructions in the operating manual.

### 2.2 Additional dangers

Before you begin using the camera system, check for visible defects and observe the system for potential faults during operation. If defects are discovered in a camera system that have a detrimental effect on safety, it must not be put in operation or must no longer be used. Defects that are detrimental to safety must be rectified before the system is placed in operation again. Dangers arising from the use of special working materials and untested, unapproved accessories, configuration, installation or operation of the device cannot be monitored. The user is therefore responsible for ensuring correct use of the products.

- ❖ Do not lay cables close to the motor or other sources of heat.
- ❖ Protect cables against damage with cable ducts or protective tubes.
- ❖ Make certain cables are not twisted.
- ❖ Cables must not be painted and must not come in contact with solvents.
- ❖ If the cable is too long, it can be routed in loops.
- ❖ Please take note of the mandatory installation radius for the camera cable: 15 x cable diameter for fixed installation, 22 x cable diameter for flexible installation.
- ❖ Do not tighten the cable connections too tightly.
- ❖ Screw the plug connections hand-tight.

# WDM-MC4000B/-VA-(Empty/A/IP)

## HEAVY-DUTY FULL COLOR OR INFRARED CAMERA

### 3.Commissioning

#### Caution:

The electrical connection and commissioning must only be performed by a knowledgeable specialist in conformity with the instructions in this operating manual.

#### 3.1 Assembly

- ❖ Install the camera in a suitable position so that the observer can see the area he needs to see.

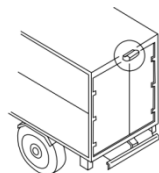

- ❖ Before beginning any mechanical tasks, make certain that no electrical parts or installation parts can be damaged. The camera must be fastened so that it does not vibrate. The assembly location must be sufficiently stable to ensure reliable fastening. .
- ❖ Please ensure that there is sufficient corrosion protection for the boreholes.
- ❖ Use the screws, washers, and other accessories in the installation kit as shown in the diagram to securely install the camera in the designated position.

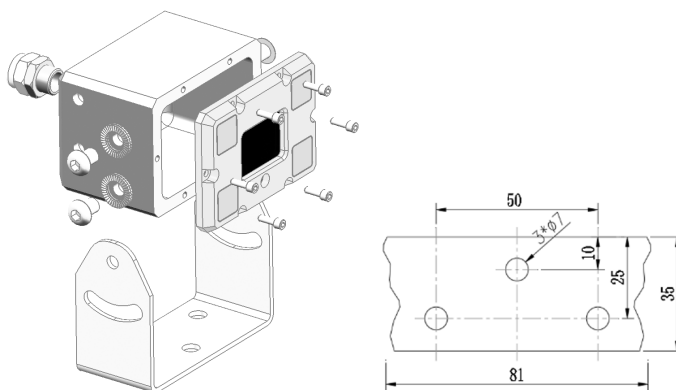

( tooth washers M6 and insulating washers M6 )

- ❖ Deburr the cable breakthrough and use cable grommets.

#### Caution:

The label is located on the bottom of the camera.

## **WDM-MC4000B/-VA-(Empty/A/IP)**

### **HEAVY-DUTY FULL COLOR OR INFRARED CAMERA**

---

#### **3.2 Electrical connection**

Connect the WDM-MC4000B to a camera input of a control unit or monitor with the appropriate connection cables. Follow the instructions in the operating manual of the instrument. For screwed plug connections, tighten the thread tight enough to ensure the plug will not leak, but not enough to over tighten or even destroy the screwed plug connection. If you use a wrench or some other tool, exercise due caution. Seal the cable connections properly with the accompanying self fusing electrical tape. To do this, unwind the tape around the plug while pulling lightly. In addition to further improving the seal, this will also provide additional protection for the screw connection and prevent it from accidentally coming loose. Use new fusing tape if you open the screw connection again later. Make certain the cables are securely fastened onto the vehicle.



#### **3.3 Functional check and camera adjustment**

Check the camera functionality after you have connected it to a monitor. Switch the camera display to mirror image. Align the camera so that the mandatory field of view is displayed on the monitor. Tighten the fastening screws on the camera completely. Seal any cable breakthroughs and check cables that were laid to ensure they are securely in place. The camera does not have any accessible controls. It is placed in operation by switching on the monitor.

#### **3.4 Faults**

If a non-function or error is detected during operation, normally the first thing to do is check the external circuit (fuse, power supply voltage, wiring, monitor etc.).

### **4、 Customer information**

Wardmay Ltd

- Service -



## **WDM-MC4000B/-VA-(Empty/A/IP)**

### **HEAVY-DUTY FULL COLOR OR INFRARED CAMERA**

512, C2 Building, Shun Jing Innovation Park, No. 3 Bai Sha Dui Road, Ji Xiang Community, \_\_\_\_\_  
Long Cheng Street, Long Gang District, ShenZhen, China.

Phone +86 15915495854

Fax +86-0755 84575180

[info@wardmay.com](mailto:info@wardmay.com)

[www.wardmay.com](http://www.wardmay.com)

#### **4.1 Maintenance/Cleaning**

The camera is maintenance-free. Clean the camera cover using a soft, slightly moistened cloth. The device is able to withstand cleaning with high-pressure or steam jet cleaners. Do not remove the labels which identify the product.

#### **5、 Environmental protection**

The packaging consists mainly of recyclable material. Use the opportunity to recycle the packaging in an environmentally responsible manner.